

VIBRATING SCREEN FOR CASTING SLIP

VBL 2500

TECHNICAL FEATURES

DATA	U.M.	VBL 2500 1/X	VBL 2500 2/X
Number screening nets	no	1	2
Screening surface	m ²	4.2	4.2+4.2
Power	kW	5	5
Centrifugal force	N	6500	6500
Weight	kg	870	1030

STRUCTURAL FEATURES

- AISI 304 stainless steel base, with ABS inspection door
- Parts in contact with the product: AISI 304 L – roughness $\leq 0.5 \text{ Ra}$
- Protection rating: IP65
- Clamping system: half-rings with bolts
- Galvanised steel diffuser with PA cone

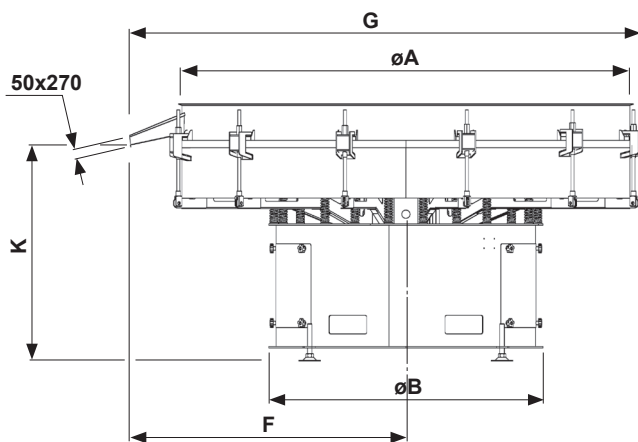

2500 1/X

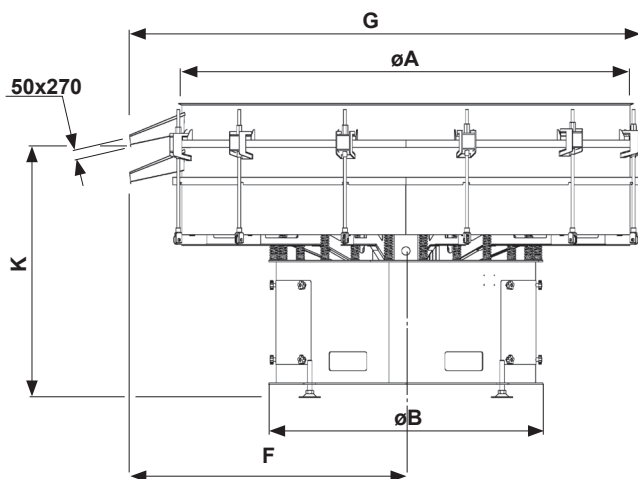
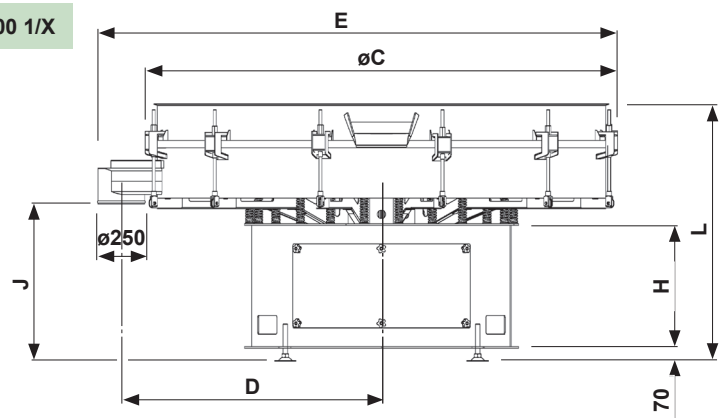

2500 2/X

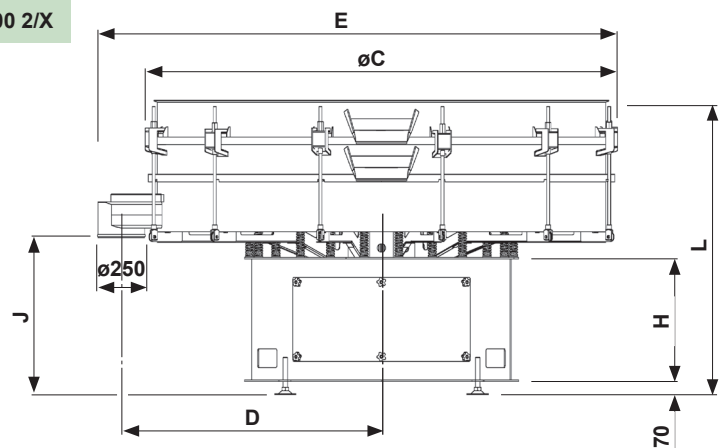

Mod./Size	øA	øB	øC	D	E	F	G	H	J	K	L
2500 1/X	2405	1472	2604	1396	2793	1479	2747	665	841	1146	1380
2500 2/X	2405	1472	2604	1396	2793	1479	2747	665	841	1345	1577

USE

- Screening of ceramic casting slips

ACCESSORIES AND VERSIONS

- Quick-coupling diffuser, protected against incrustations
- Lid unit with pneumatic lifting
- Screen washing system with crown of nozzles
- Feet for leveling vibrating screen

The information is approximate - The guaranteed values are released by Vibrotech s.r.l. on request-It is forbidden to reproduce the document even partially.