



1

USE AND MAINTENANCE INSTRUCTIONS

POWDER DISSOLVER
EMT - ECD

Code:22112018.EMT-ECD

ENGLISH

Publication issued by: **VIBROTECH s.r.l.**

Edition: It11/18

© 2016 - All rights reserved

This manual is:

- an integral part of the supply and must be read carefully to ensure proper use in compliance with the essential safety requirements;
- the English translation of the original written in Italian.

VIBROTECH s.r.l. shall not be held liable for damage resulting from operations not covered in this manual.

13/02/2017	Page 4-9; 5-2	Rev. 01
27/06/2017	Page 1-6; 2-4; 4-10; 4-12; 5-3; 5-4; 5-5; 5-6.	Rev. 02
22/11/2018	EMT - EDC - Page 7-1 (annex eliminated)	Rev. 03
28/06/2019	Page 4-10	Rev. 04

CONTENTS

1	General information	1-1
1.1	Introduction	1-2
1.2	Topics covered in the manual, meaning of number references	1-2
1.3	How to update the information	1-2
1.4	Manual symbols	1-3
1.5	Terms and abbreviations	1-3
1.6	Worker qualifications	1-4
1.7	Worker training	1-4
1.8	Collaboration with the user.....	1-5
1.9	Warranty	1-5
1.10	Technical assistance.....	1-6
1.11	List of attachments	1-6
2	Description and technical specifications	2-1
2.1	Machine Description.....	2-2
2.2	Identification.....	2-2
2.3	Main parts	2-3
2.3.1	Electrical system	2-4
2.3.1.1	Main electrical panel.....	2-4
2.3.2	Hydro-pneumatic system.....	2-5
2.3.2.1	Pneumatic panel.....	2-5
2.3.2.2	Hydraulic and pneumatic diagram	2-5
2.3.3	Protections, safety and signalling devices	2-6
2.4	Intended use	2-7
2.4.1	Characteristics of the operating environment.....	2-8
2.4.1.1	Lighting	2-8
2.5	Noise.....	2-8
2.6	Vibrations	2-9
2.7	Unintended use	2-9
2.8	Technical data and limits of use	2-10
3	Safety and accident prevention	3-1
3.1	General safety warnings.....	3-2
3.2	Danger zones and operator work-stations	3-3
3.3	Residual risks.....	3-4
3.4	Warning plates	3-5
3.5	Personal protective equipment.....	3-6

4	Installation and start-up	4-1
4.1	Delivery	4-2
4.1.1	Unloading from the transportation vehicle	4-2
4.2	Content check - packaging disposal	4-3
4.3	Storage	4-4
4.4	Transport and lifting	4-5
4.5	Set-ups provided by the Customer/User	4-6
4.5.1	Characteristics of the rooms	4-6
4.6	Installation	4-7
4.6.1	Installing the Machine on the floor	4-7
4.6.2	Installation of Flocculating agent tank (optional)	4-8
4.6.3	Installation of pipes.....	4-8
4.6.3.1	Powder supply connection	4-9
4.6.6	Electrical connection	4-10
4.6.6.1	Electrical connection of Load cells.....	4-10
4.6.7	Pneumatic connection.....	4-11
4.7	Commissioning	4-12
4.7.1	Checking correct activation	4-12
4.7.1.1	Checking the direction of rotation of the motor	4-12
4.7.1.2	Checking operation of Load cells	4-12
5	Use and operation	5-1
5.1	Operating principle	5-2
5.2	Control devices	5-3
5.2.1	Push-button board	5-3
5.2.2	Operator panel	5-4
5.2.3	Analogue weight transmitter	5-4
5.3	Operating procedures.....	5-5
5.3.1	Switch-on.....	5-5
5.3.2	Starting the work cycle	5-5
5.3.3	Normal voluntary stop.....	5-5
5.3.4	Emergency stop.....	5-6
5.3.4.1	Resetting after an emergency stop	5-6
5.4	Additional operations.....	5-6
5.5	Using the work program	5-6
6	Maintenance	6-1
6.1	Safety warnings.....	6-2
6.2	General rules for good maintenance	6-2
6.3	Safe maintenance procedure	6-3
6.4	Scheduled routine maintenance	6-4
6.5	Special maintenance.....	6-4
6.6	Troubleshooting.....	6-5
6.7	Dismantling.....	6-6
6.8	Maintenance register	6-7
6.9	Ordering spare parts	6-9

1 General information

1.1 Introduction

The manual describes the instructions for safe use and maintenance of the POWDER DISSOLVER, from here on shortened to “MACHINE”.

At the time of delivery ensure that the Machine is complete with all of its parts.

Any anomalies must be notified immediately to the dealer or manufacturer.

Before operation, operators are reminded to read it carefully, to avoid damage to people and/or property.

The manual describes two machine models:

1. EMT;
2. ECD.

1.2 Topics covered in the manual, meaning of number references

The following topics are described in the manual:

1. Intended use;
2. Technical data and limits of use;
3. The main components of the machine;
4. Aspects connected to operator safety;
5. Installation, operation and maintenance;
6. Troubleshooting.
7. Annexes (example: Wiring diagrams)

Spare parts are identified in manual number “2”, downloadable from the WEB portal.

The page numbers start over again at the beginning of each chapter; we therefore have a prefix for the chapter number followed by the progressive page number.

The number of the figures refers to the associated paragraph.

Example fig 4.2-3 means:

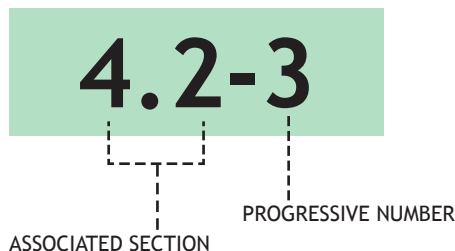

1.3 How to update the information

Proceed as follows, if the manual needs to be updated after repairs and/or changes authorised in writing by VIBROTECH s.r.l:

- send a copy of the changes to be incorporated into the Technical Dossier to VIBROTECH s.r.l;
- VIBROTECH s.r.l shall update the information and send an updated copy of the new edition.

IMPORTANT!

A change to the Machine that could result in new risks requires a new CE marking and updating of the manual.

1.4 Manual symbols

DANGER!

This indicates situations that pose a risk for people, drawing the reader's attention to accident prevention measures and providing advice on conduct.

WARNING!

This draws the reader's attention to risks to the Machine and/or the product being processed.

IMPORTANT!

This marks useful tips on consulting the manual and on optimal use of the Machine.

1.5 Terms and abbreviations

- **Machine:** POWDER DISSOLVER model EMT - ECD
- **E.P.:** Electrical Panel.
- **Operator - Worker:** any person qualified to use the Machine
- **Exposed person:** any person wholly or partially in a danger zone
- **Danger zone:** any zone within or around the Machine where a person's health or safety is at risk.
- **P.P.E.:** Personal Protective Equipment.
- **Service:** Technical Assistance Centre.

1.6 Worker qualifications

Machine operation must be assigned to staff who are trained in its characteristics and all of the safety rules adopted by the employer for safe operation.

Operators must be familiar with the contents of the manual, and possess the following requisites, or acquire them through relative training.

- A general and technical preparation that enables them to understand the contents of the manual regarding use and maintenance instructions, and to correctly interpret the drawings and diagrams they contain;
- A knowledge of the main hygiene, accident prevention and technological rules relative to the adopted productive process;
- Specific experience with the employed technology;
- General knowledge of the composition of the equipment installed on the Machine, especially the position of the devices for emergency stops and disconnection from power sources;
- Know what to do in case of emergency, where the personal protective equipment is and how to use it correctly;
- Sufficient training to skilfully carry out tasks, especially during emergencies

In addition to the above, the maintenance technicians must also have the basic technical knowledge required to perform the necessary interventions. In particular, they must know the main construction characteristics of the Machine

1.7 Worker training

If required, **VIBROTECH s.r.l.** provides direct training for user staff tasked with operating the Machine

During the training period, with the appointed individuals, all the topics contained in the supplied documentation will be analysed, to guarantee full understanding and to memorise what is required to perform every operation in completely safe conditions.

When training is complete, the authorisation, final testing and Machine transfer documents will be drawn up and signed by both parties.

Before fulfilling these conditions, it will NOT be possible to use the Machine

Failure to observe this condition will relieve the manufacturer of any liability for any damage caused to people or property.

1.8 Collaboration with the user

- The manual reflects the state of the art at the time when the Machine was placed on the market, of which it is an integral part.
- Any integrations to the manual deemed necessary by VIBROTECH s.r.l. and sent to the users must be kept with the manual.
- VIBROTECH s.r.l. is available to its clientele to provide additional information and to consider suggestions for improvement in order to make this manual more compliant with the needs it was prepared for.
- When the Machine is transferred the primary user is asked to inform VIBROTECH s.r.l. of the address of the new User so that they can contact them for future correspondence and/or essential updates.

1.9 Warranty

VIBROTECH s.r.l. Via Don Pasquino Borghi, 4 - 41043 Casalgrande (RE) “Manufacturer” of the Machine referred to herein, provides a Warranty for factory defects for a period of 12 months.

The Warranty is only valid if the Machine is used according to the Manufacturer’s instructions and has not been tampered with.

The Warranty period begins on the date that the customer signs the Machine’s final test Report on or from the date when the Machine left the manufacturer for shipment to the customer.

The Warranty includes replacement of faulty parts. The labour required to replace the faulty parts and the out-of-pocket expenses (transport, room and board, etc.) are paid by the customer. Parts that are subject to wear are not covered by the Warranty.

IMPORTANT!

The warranty lapses immediately if any technical repair work is carried out on the Machine by unauthorised staff.

1.10 Technical assistance

Refer to the Technical Assistance Service (SERVICE) at the contacts provided below to request assistance from the manufacturer and to order spare parts. Always specify the identification data of the machine (Type, Model, Year and Serial Number)

VIBROTECH S.r.l.

Operational Headquarters: Via Don Pasquino Borghi, 4 - 42013 CASALGRANDE (RE) - Italy
Tel. +39 0536 82.37.76 - Fax +39 0536 81.20.09
www.vibrotech.biz - email: info@vibrotech.biz

1.11 List of attachments

1. Declaration of conformity
2. Operator panel user manual
3. Analogue weight transmitter Installation and use manual
4. Wiring diagrams

IMPORTANT!

Request the attachments listed above at service@vibrotech.biz.

IMPORTANT!

The WIRING DIAGRAM is in Annex I of this manual.

2 Description and technical specifications

2.1 Machine Description

IMPORTANT!

For the technical characteristics of the models, refer to the Technical Data Sheets that can be downloaded from the WEB portal.

2.2 Identification

IMPORTANT!

It is forbidden to remove, damage or modify the data provided on the plate.

	Via Don Pasquino Borghi, 4 42013 S.Antonino (RE) Italy Tel.+39.0536.823776				
Modello	<input type="text"/>				
Matricola	<input type="text"/>				
Volt	<input type="text"/>	Hz	<input type="text"/>	<input type="text"/>	<input type="text"/>



2.3 Main parts

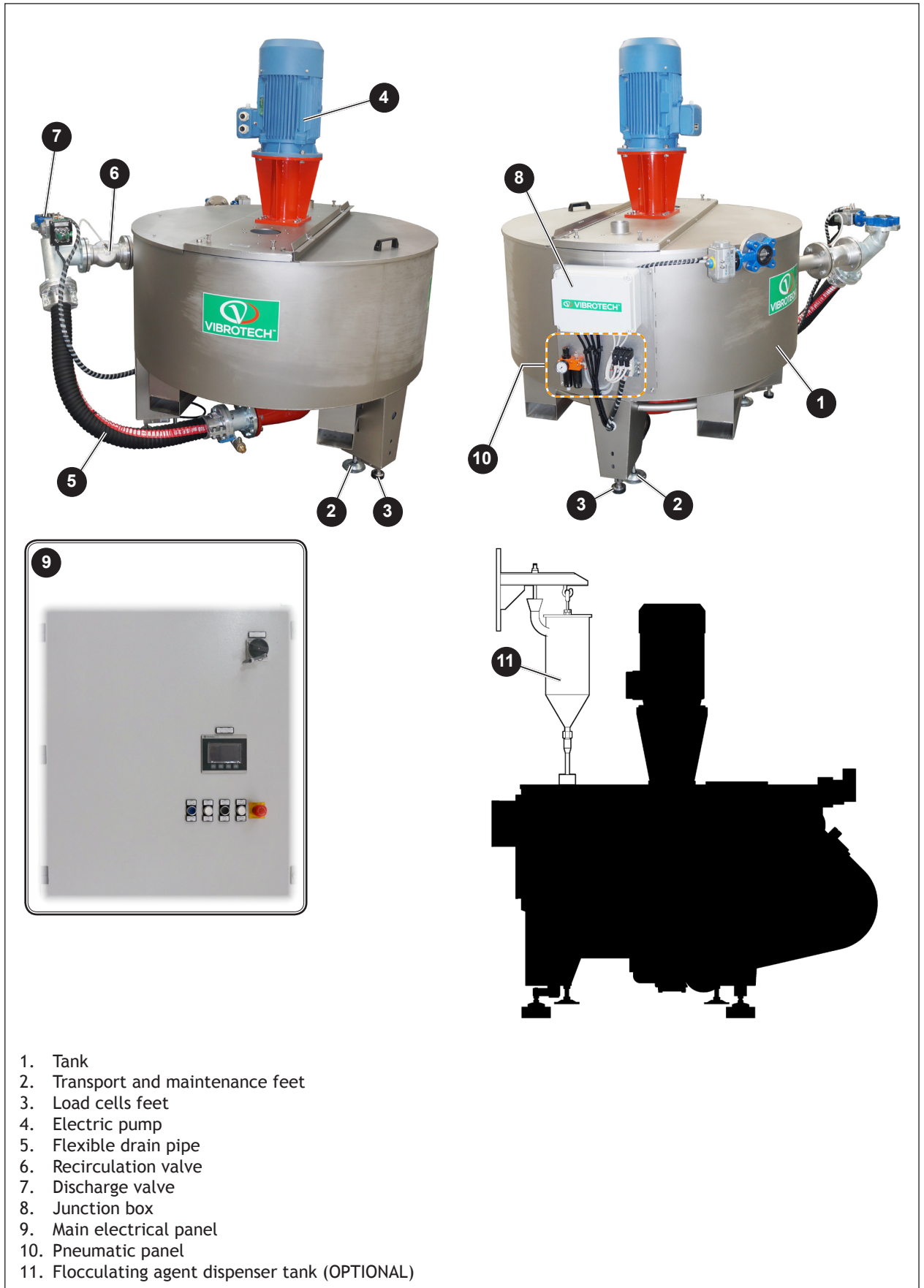

2.3.1 Electrical system

The electrical system is comprised of:

1. Electrical panel with operator panel and pushbutton panel
2. A series of components on the Machine

DANGER!

Prior to any work on the Machine, disconnect the electrical supply line. Only Qualified operators can work on live components.

WARNING!

To activate the Machine, the tank must be earthed. The supply voltage must be stable +/- 5%.

2.3.1.1 Main electrical panel

The Electrical panel in question is designed to control the following devices:

- Inverter-controlled circulation pump motor
- 24 Vac water filling solenoid valve
- 24 Vac circulation solenoid valve
- 24 Vac emptying solenoid valve



ELECTRICAL PANEL TECHNICAL DATA

Rated current	52 A
Rated voltage	350-550 V
Frequency	50/60 HZ
IP Protection rating	55

The Operator panel is described in the "Operator panel user manual" (request the document at service@vibrotech.biz)

2.3.2 Hydro-pneumatic system

2.3.2.1 Pneumatic panel

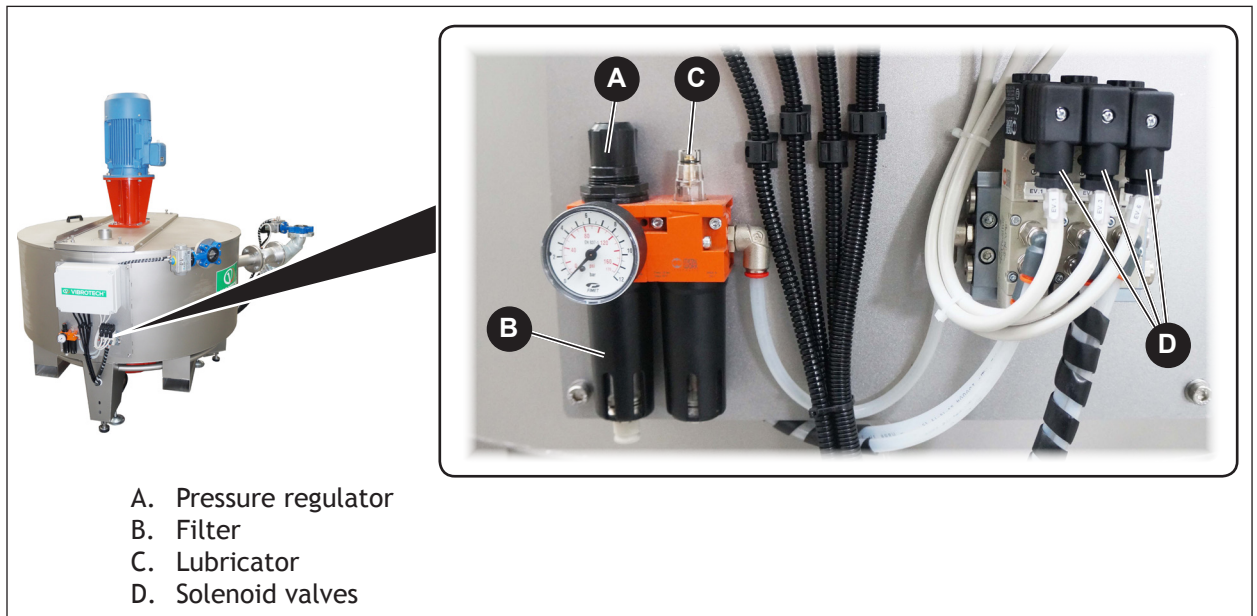

2.3.2.2 Hydraulic and pneumatic diagram

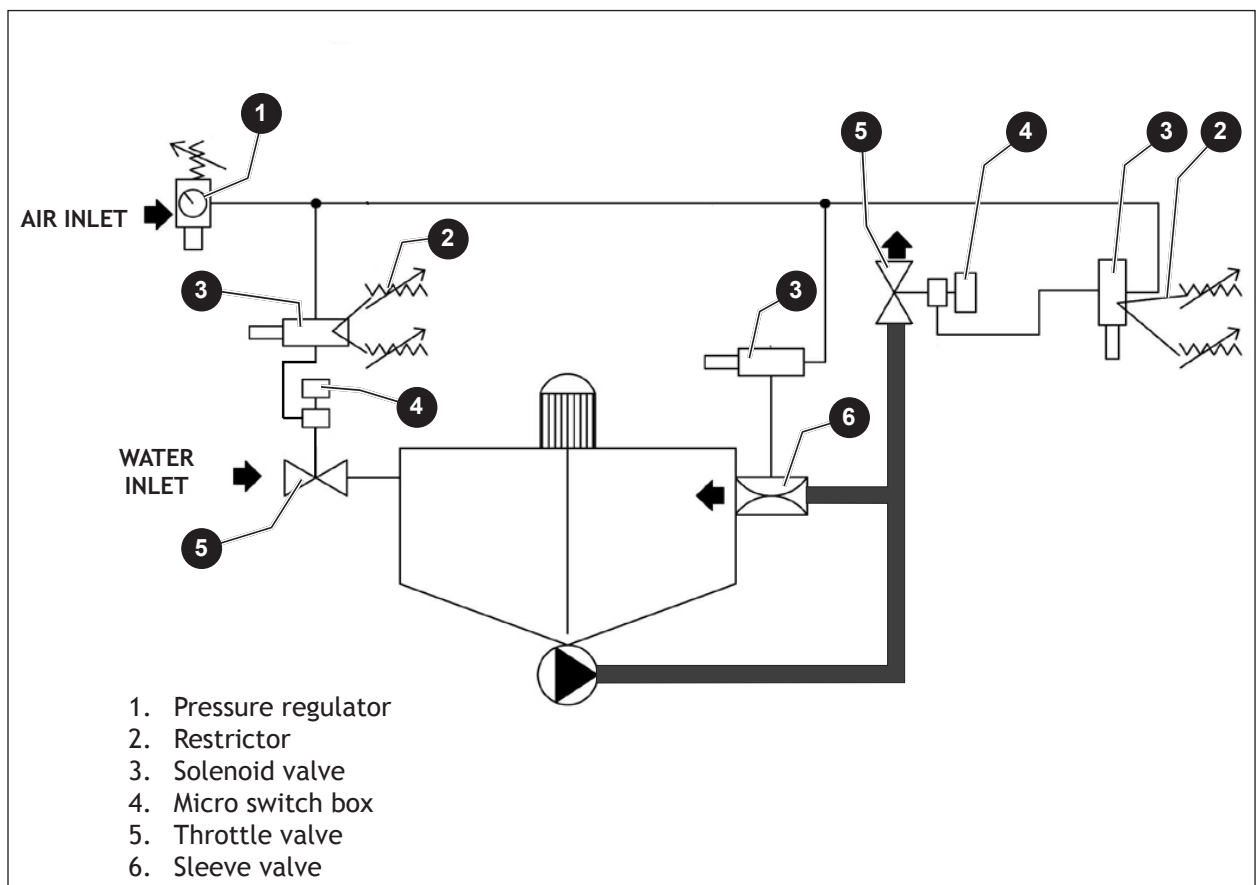

WARNING!

Adjust the restrictors of the above controlled valves in order to close slowly and to avoid water hammers.

2.3.3 Protections, safety and signalling devices

DANGER!

The lack or disabling of protections, of safety and signal devices does not entail malfunctioning or production defects, can cause DANGEROUS SITUATIONS FOR THE OPERATORS.

DANGER!

It is not allowed to use the Machine or a part of it, if it has not been correctly installed with all the safety devices intact and functioning. The Manufacturer disclaims any liability arising from the non-use of safety devices.

DANGER!

It is not permitted to make changes to the SAFETY DEVICES that adversely affect its operation or add additional risks not covered by the manufacturer. Every functioning modification must be communicated and approved in writing by the MANUFACTURER. Modifications which alter risks, if done without the written permission of the manufacturer, will automatically invalidate the EC declaration of conformity of the Machine.



Regardless of the adopted protections, some Residual Risks remain, as described in Par. 3.3

2.4 Intended use

The Powder dissolver was designed and built to process fine powders (particles with maximum diameter \varnothing 5 mm) at the discharge of filters or in cyclone separators.

The Machine is equipped with a weighing system, consisting of load cells which calculate the dosage between water and powder.

All maintenance activities need to be carried out with the Machine switched off.

DANGER!

Maintenance and adjustments must be carried out with the Machine switched off, with the exception of specific conditions under the responsibility of specialised and/or authorised staff.

The designer of the work place is responsible for defining the limits concerning the presence of staff, and may entail more restrictive limitations.

DANGER!

Any exceptions to the above in terms of ambient requisites for correct Machine operation, require a specific written declaration from the MANUFACTURER.

2.4.1 Characteristics of the operating environment

Min - max operating environment temperature (°C):	5 - 50
Max. temperature gradient (°C/h)	10
Max relative humidity (Max RH).....	10 ÷ 95%
Max. altitude above sea level (m)	1000

DANGER!

The workplace MUST NOT pose any risks of explosion or fire, as the Machine is not explosion-proof. The work area must be kept dry and clear of any obstacles. The safety distances for cleaning and/or maintenance operations must be observed. There must not be any fixed obstacles that could limit movements.

Any traffic lanes for forklifts must be marked with adequate signs and/or, preferably, with markings on the floor.

WARNING!

If the ambient conditions are particularly critical, it is advisable to equip the area with a suitable air conditioning system to maintain the humidity and temperature values within acceptable limits.

WARNING!

The set-ups provided by the user are described in par. 4.4

2.4.1.1 Lighting

The work place must have sufficient natural light (whenever possible) and it must be equipped with devices that provide adequate artificial light needed to protect the safety and health of the operator.

The minimum lighting in the room (value between 300 and 500 lux) must ensure good visibility in every point of the line and must ensure the correct perception of the symbols and pictograms. Maximum illumination must not blind the operator.

2.5 Noise

The weighted equivalent continuous sound pressure level generated by the Machine is less than 70 dB(A). The measurement was taken on a Machine in operation near the operator work stations.

DANGER!

The value refers to the Machine alone. This value, therefore, must not be taken into consideration as the exposure level to which OPERATORS ARE EXPOSED IN THE WORK ENVIRONMENT IS GREATER. Inspections must be made to determine the acoustic pressure level and to assess whether personal protective measures need to be used.

2.6 Vibrations

The Machine does not produce vibrations that create:

- a danger to the operators' health;
- disturbance to the surrounding environment, which can affect stability and accuracy of the equipment placed in the vicinity.

2.7 Unintended use

Failure to comply with the following relieves the manufacturer from any liability.

IT IS FORBIDDEN to even partially use the Machine in one or more of the following conditions:

- in explosive atmospheres;
- in outdoor, unprotected areas differing from the requirements set forth in par. 2.4.1;
- without protections and/or with safety devices deactivated, faulty or missing;
- if installed incorrectly;
- in dangerous conditions or if there are any malfunctions;
- for use contrary to specified standards;
- in the event of a fault with the power supplies (electrical, compressed air, etc.);
- after any modification or work that is not authorised by the Manufacturer;
- for use other than the purpose it was designed for by the Manufacturer (improper use);
- by untrained personnel;
- in case of partial or total failure to follow the instructions;
- executing operations that are not reasonably foreseeable;
- poor maintenance;
- if non-original spare parts or parts unauthorised by the Manufacturer are used;

Contraindications and dangers of unintended uses

The Machine is calibrated and tested by the Manufacturer according to the specifications requested by the customer.

- Do not work on the mechanisms with the intention of changing the intended operating cycle.
- Do not use products differing from the admissible ones.

DANGER!

It may be harmful to feed in materials that differ from the Machine's specifications.

DANGER!

- *These conditions refer to Machine use. The designer of the work place(s) is responsible for defining the limits concerning the presence of staff, and may entail more restrictive limitations.*
- *A specific written statement by the manufacturing company, VIBROTECH s.r.l, is required for exceptions to the above.*
- *It is not allowed to modify parts of the Machine or safety devices that jeopardise its function or add further risks, not considered by the manufacturer. Every modification to operation must be communicated and approved in writing by the manufacturer.*
- *Any change that modifies the risks, if performed without the authorisation of the manufacturer, will void all warranties and the EC declaration of conformity.*
- *The Manufacturer will not be liable also in case of exceptional events such as earthquakes, floods or fires not directly caused by the Plant/Machine.*

2.8 Technical data and limits of use

Refer to the technical data sheet that can be downloaded from the WEB portal.

3 Safety and accident prevention

3.1 General safety warnings

- 1) Do not allow UNTRAINED personnel to intervene on the Machine.
- 2) DO NOT START UP A FAULTY MACHINE
- 3) Before using the Machine, ensure that any hazardous condition for safety has been appropriately eliminated.
Check that all protections (guards, safety devices) are in place and perfectly efficient.
- 4) Every maintenance operation must be carried out with the Machine disconnected from power distribution systems (electric, pneumatic and other).
- 5) Use goggles with side guards and, if necessary, helmets or gloves when there is any possibility of being struck by thrown or falling objects.
- 6) Before any manual intervention on the Machine or on the processed material, the Machine must be deactivated by performing the "SAFE MAINTENANCE PROCEDURE".
- 7) ELECTRICAL EQUIPMENT
Connections, commissioning, maintenance, measurements and adjustments on the electrical equipment or its components must be carried out only by qualified personnel.
- 8) Remember that frequency converters (inverters) generate dangerous voltages which could be fatal. Before intervening on these devices, if installed, read the relative documentation supplied by the manufacturer of the device or contact the manufacturing company.
- 9) For any work that needs to be carried out on live parts, it is necessary to observe the applicable standards in force in the country of use.

DANGER!

IT IS FORBIDDEN TO:

- *start up the Machine without having first made sure that there is nobody near the danger zones and there are no foreign objects on the machines. Make sure that start-up is not dangerous to staff;*
- *remove or deactivate protections (guards and safety devices). Temporarily disabling the protections is only permitted to perform maintenance;*
- *perform adjustments or maintenance while in Automatic mode;*
- *work on moving or electrical parts without having firstly disconnected power;*
- *tamper with or remove the safety labels applied to the Machine;*
- *make changes to the Machine without the consent of the manufacturing company;*
- *act on the control devices without possessing the required skills;*
- *disable the safety devices of the Machine or of the work zone or to use them improperly;*
- *throw water on motors or on electrical components;*
- *drill holes on conduits or in the ducts of electric cables.*

DANGER!

IT IS MANDATORY:

- *to read and understand all of the documentation provided with the Machine prior to operation;*
- *to wear protective equipment that is suitable for the operations to carry out;*
- *to maintain the safety systems and the emergency buttons in good working order;*
- *to maintain the control instruments in good working order and legible, replacing them when damaged;*
- *to make sure there are no oil or fluid leaks when the Machine is operating. Check that the electric components work regularly and that the motors do not smoke. Do not ignore unusual odours or noises;*
- *to stop the Machine as soon as a malfunction develops;*
- *to apply warning signs on the electrical panel and to lock the main switch in the event of malfunctioning or maintenance;*
- *to maintain the pictograms on the Machine and the controls on the push-button panels in good condition and ensure they are always legible;*

3.2 Danger zones and operator work-stations

IMPORTANT!

The operator can stand anywhere in the vicinity of the Machine because the danger zones are inside of it. The protections adopted to prevent dangerous situations are described in paragraph 2.3.3.

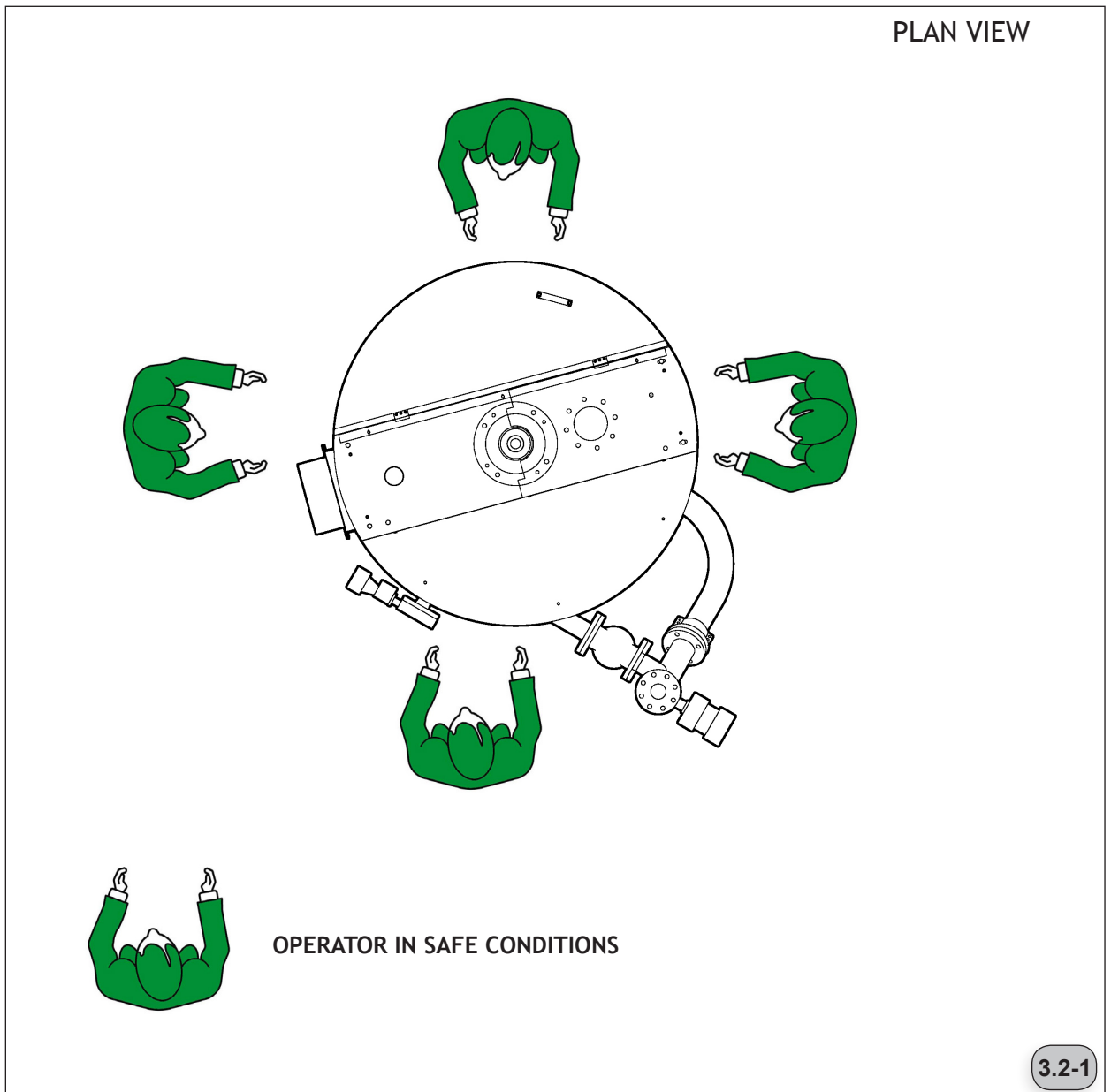

3.3 Residual risks

In spite of the protections and safety systems adopted on the Machine (described in paragraph 2.3.2), dangerous conditions remain for the operators and/or maintenance technicians, which could occur if the recommendations below and indicated in the safety signs described in paragraph 3.4 are not observed. Figure 3.3-1 illustrates the hazardous points where it is possible to run into the residual risks described below.

The appointed maintenance technician is subject to the following dangers only during maintenance operations:

R1. DANGER MOVING PUMP TRACTION AXIS

Risk of crushing/dragging.

In the work zone of the motorised vibrator. Do not remove protection "A" with the machine on. Before starting operation, run the "Place in maintenance mode" procedure.

R2. DANGER OF HIGH TEMPERATURES IN THE MOTOR

Risk of burning

The Motor can reach temperatures of up to 60°C. DO NOT TOUCH THE MOTOR during Machine operation. Wear protective gloves before touching or handling them.

R3. DANGER 400 Volt and 230 Volt

Risk of electrocution.

In the terminal boards of the electrical box and in the Electrical panel. Before operating, perform the "Place in maintenance mode" procedure which indicates disconnecting the electric power.

Danger reported with plate "1" (Fig. 3.4-1);

IMPORTANT!

- Only trained and authorised operators can work on live parts.
- Depending on the country of destination of the Machine, there can be different types of voltage inside of it.



DANGER!



IT IS PROHIBITED TO:

- APPROACH OR PLACE ANY PART OF THE BODY IN THE MACHINE WHEN IT IS MOVING OR CONNECTED TO THE POWER SOURCES
- TOUCH MOVING OR LIVE PARTS
- DISABLE THE SAFETY SYSTEMS
- PERFORM ANY OPERATION WITHOUT FIRST HAVING PERFORMED THE SAFE ACCESS AND MAINTENANCE PROCEDURES
- WORK IN ELECTRICAL PANELS WITHOUT AUTHORISATION
- ACCESS THE WORK AREA WEARING DANGLING OBJECTS THAT MAY GET HOOKED ONTO MOVING PARTS

3.4 Warning plates

WARNING!

Make sure all of the plates are clearly legible, otherwise replace them with new ones in the exact same position.

Pos.	PICTOGRAM	DESCRIPTION
1		Presence of voltage indicated on the bottom label Only specialised personnel can work on live electrical components Risk of electric shock.
2		Read the manual before conducting any work;

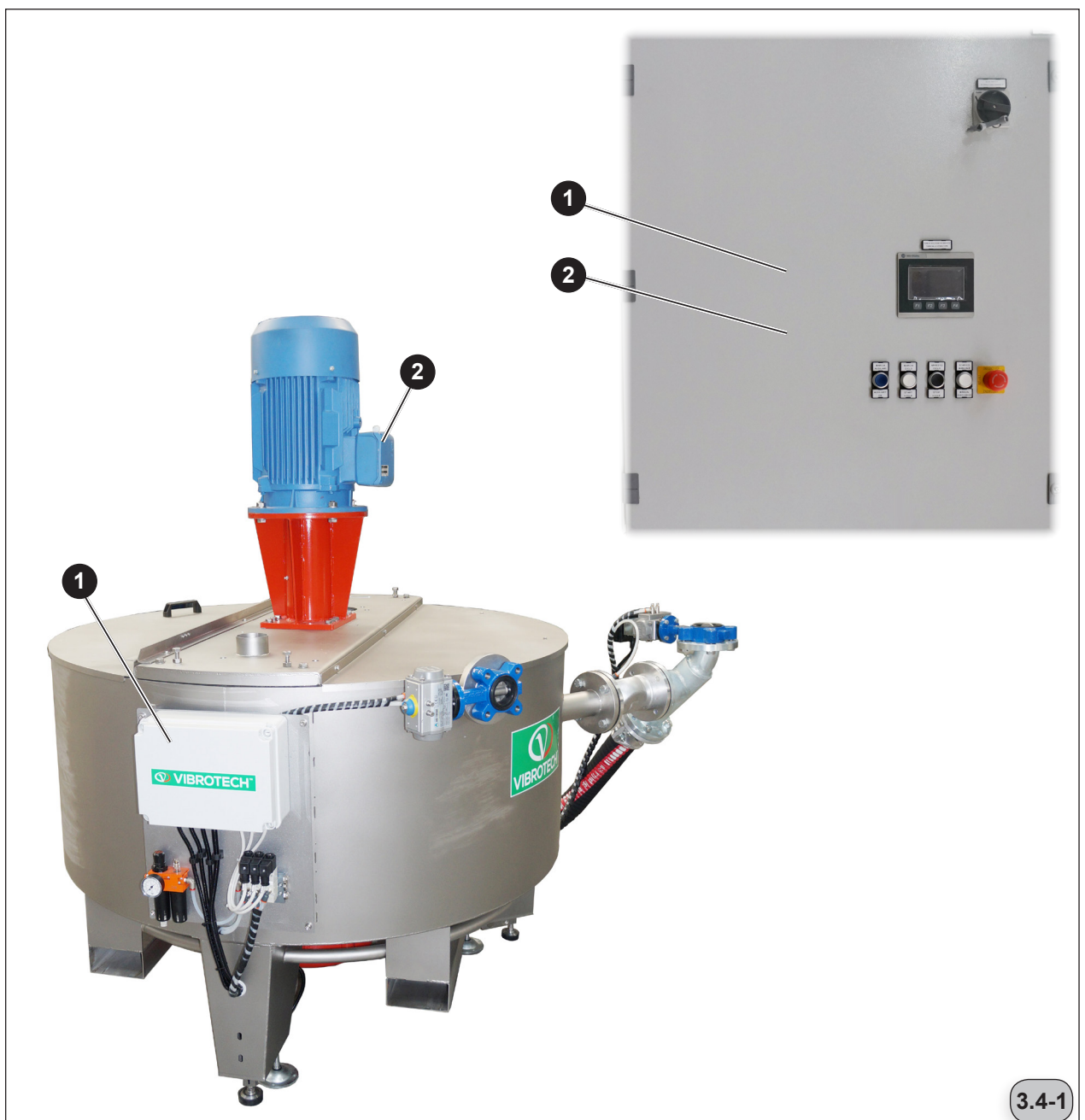

3.4-1

3.5 Personal protective equipment

In addition to the personal protective equipment related to safety in the workplace, in the country of use of the Machine, it is necessary to use the following personal protective equipment:

- wear gloves when replacing and/or adjusting the parts.

4 Installation and start-up

4.1 Delivery

WARNING!

Staff in charge of loading, unloading and handling must have the skills and acquired and recognised experience in the specific sector and must be familiar with the necessary lifting equipment.

WARNING!

Lifting and transport equipment must be chosen based on the weight, shape and size of the Machine.

4.1.1 Unloading from the transportation vehicle

Based on the country of destination, the Machine is delivered fully assembled, covered with shrink-wrap and packaged on:

- pallet (A), if shipped by land or in Container;
- wooden crate (B) on request or with air shipment.

The weight of the load to be lifted is provided in the identification document (D) applied to the packaging.

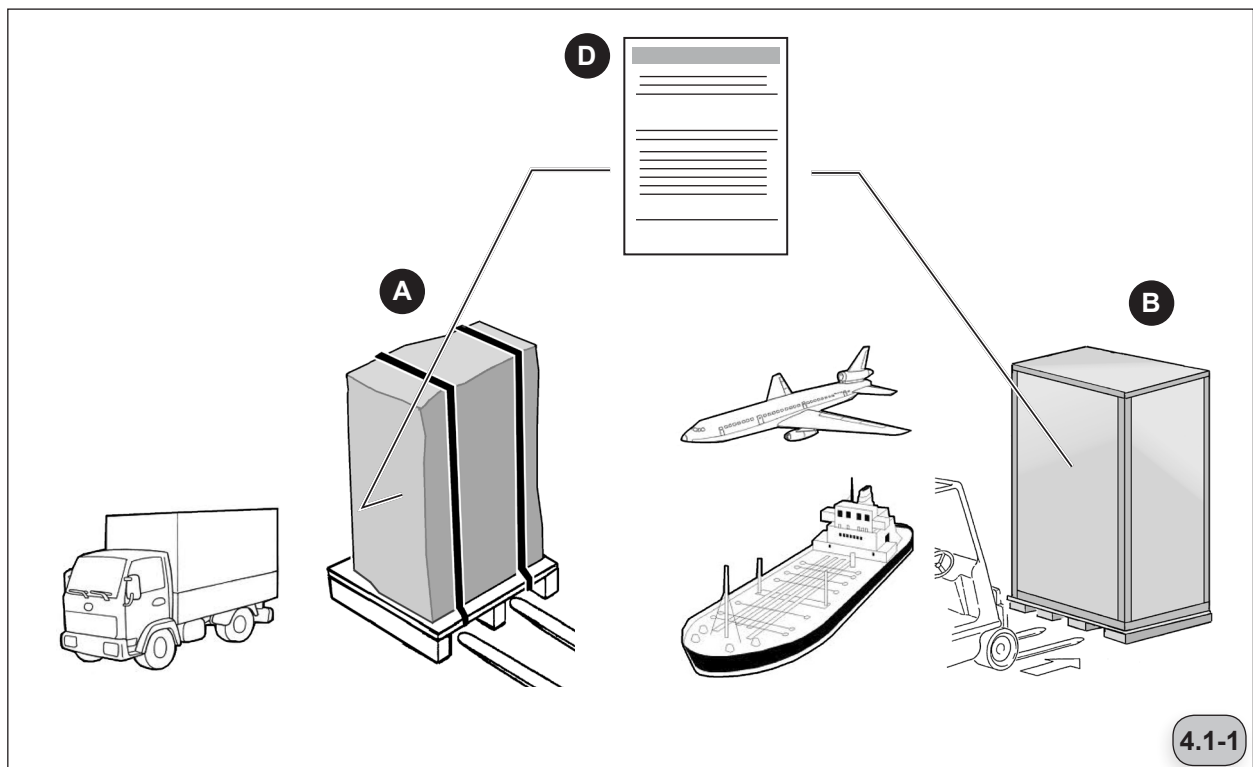

IMPORTANT!

For the correct and safe lifting and handling of the package, you must observe the points below:

- *Use a suitable lifting system in terms of capacity and size of the package*
- *Staff must be competent, in possession of the qualifications required by the regulation in force, in order to guarantee the driver and his/her co-workers maximum safety at work*

4.2 Content check - packaging disposal

The entire Machine is thoroughly checked before shipment. When receiving the packaging make sure it has not been damaged during transport, in particular check that the packaging has not been tampered with, resulting in parts being removed from it. If damage or missing parts are noted, immediately notify the carrier and the Manufacturer, and show the relative photographic documentation.

IMPORTANT!

If any kind of damage is detected, a claim must be made with the driver of the means of transport. Contact the dealer or Manufacturer immediately.

WARNING!

The manufacturer will not be responsible for damage caused to the Machine when transported and placed inside the premises by third parties.

The crate must be opened as follows:

- remove the top cover;
- take down the side walls;
- remove the waterproof material and the parts fastened to the Machine being careful to support them during the removal phase;
- remove the additional fastening elements;
- make sure the Machine has not been damaged during transport, and immediately notify the Manufacturer if it has.

IMPORTANT!

The material used for packaging must be disposed of in accordance with the regulations in force in the country of use.

4.3 Storage

If any parts of the Machine need to be stored for extended periods of downtime, it is advisable to keep them protected against weathering (ideally in their original packaging), and in rooms with characteristics that meet the levels of protection described below:

- Temperature: -10/+45 °C;
- Relative humidity 45% Max (not condensate);
- Indoor facilities protected from the weather.

WARNING!

*Values other than those indicated above may seriously damage the components.
Do not place heavy objects on the packaging.*

WARNING!

- *Values other than those indicated above may seriously damage the components.*
- *Do not place heavy objects on the packaging.*
- *If the packaging has been removed, keep the Unit in a covered area that ensures protection from the elements and from harsh chemical agents*

4.4 Transport and lifting

Lift the Machine using fabric straps suitable for the weight being lifted. Position the Machine in the area where it will be used.

DANGER!

Lifting and handling operations must be done by personnel that are qualified and authorised for this type of manoeuvre, and equipped with all the necessary safety devices, such as:

- *safety footwear*
- *protective helmet*
- *safety hook with relative harness (for operators working at a height), etc...*
- *gloves.*

No one must be near the suspended load and/or in the range of action of the lifting equipment while the Machine is being lifted and handled.

DANGER!

The load must remain perfectly parallel to a horizontal plane during handling, regardless of the type of equipment used.

An assistant is required during load lifting and transport operations for any necessary signalling.

Lifting must be constant, without jerks or sudden movements.

Perform lifting in a continuous manner, making sure that the lifted load is perfectly balanced.

It is forbidden to walk and stand under suspended loads.

Before lifting the various Machine parts, you must observe the following precautions:

- Send all operators to the safety position.
- Be sure the load is stable.
- Make sure there is no material that could fall during lifting.
- Manoeuvre vertically so as to avoid hitting things.

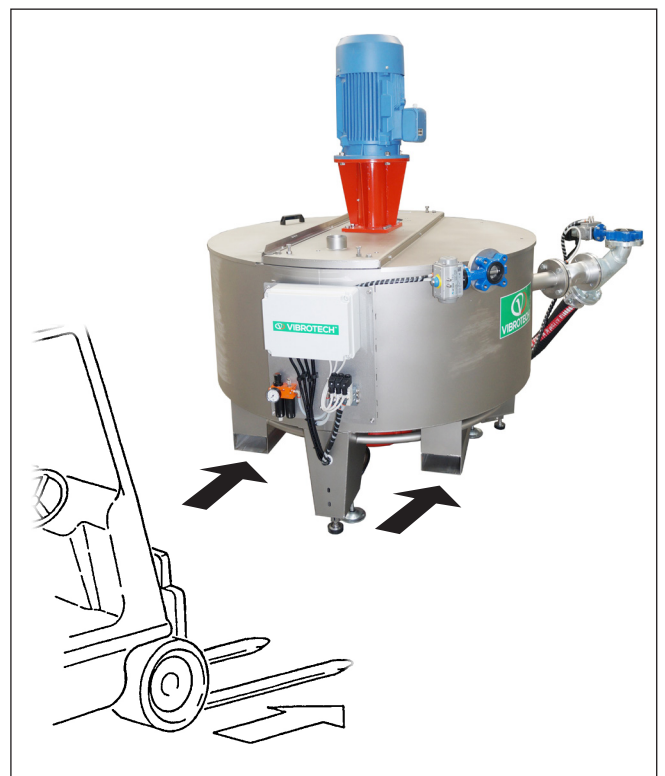

DANGER!

The Manufacturer declines any liability for damage to property or people resulting from the failure to observe the existing safety regulations with regard to lifting and handling materials inside the User's plant.

4.5 Set-ups provided by the Customer/User

Properly preparing and checking the workplace is an essential requirement for the Machine to operate correctly and safely.

It is the responsibility of the User to provide:

- the room where the Machine will be used (see paragraph 2.4.1).
- the spaces required to handle and store materials;
- the traffic lanes for the lifting equipment (forklifts, cranes, etc) must be clearly visible to the operators;
- the areas where operators are stationed for plant/machine use and maintenance (see paragraph 4.5.1);
- the power supply connection must comply with the regulations in force and must provide an efficient earthing system, a switch with automatic protection against short circuits, ground discharges and losses between the power line and the machine line. The voltages must be compatible with those required for the Machine. A delayed differential switch must be adopted and installed upstream of the plant (see paragraph 4.6.6)

DANGER!

After installation, check the effective sound pressure value that has developed in the area where the Machine operates, to define whether it is necessary to use protection measures for the operators.

4.5.1 Characteristics of the rooms

The room in which the Machine will be positioned must have the characteristics described in paragraph 2.4.1

The areas intended for the operators must be large enough for operation and maintenance.

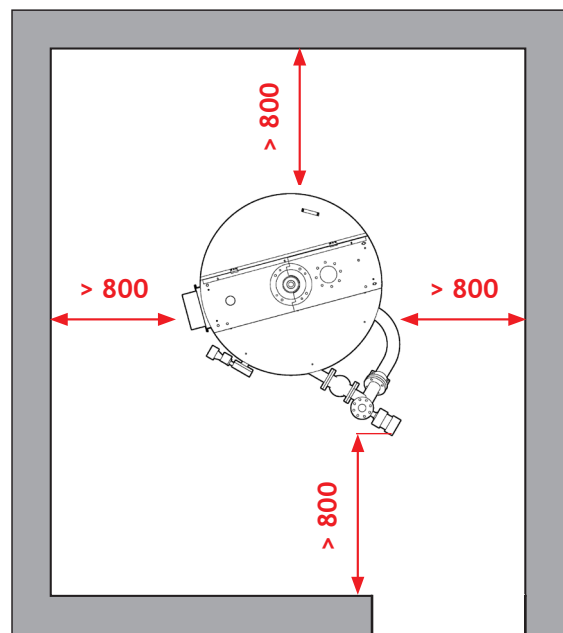

DANGER!

The work area must be kept dry and free from obstacles. The passageways around the unit must be able to ensure that the safety distance is respected (greater than 800 mm). There must not be any fixed obstacles that could limit movements. Any traffic lanes for forklifts must be marked with adequate signs or, preferably, with markings on the floor.

4.6 Installation

WARNING!

The construction, size and functional characteristics of the parts are such that they require the Customer/User to possess specific expertise that can only be guaranteed by the Service Technicians. If the User encounters difficulties performing the listed operations on his/her own, he/she is required to contact the manufacturer, to request information on training.

4.6.1 Installing the Machine on the floor

WARNING!

The floor should be made with reinforced concrete and must be perfectly level.

1. Set the Machine on the floor without fastening it
2. Lift the transport feet "A"
3. Level the Machine using the adjustable feet "B" of the load cells.
4. Place a level on top of the Machine to check correct levelling.
5. Make the electrical connection as indicated in the wiring diagram.

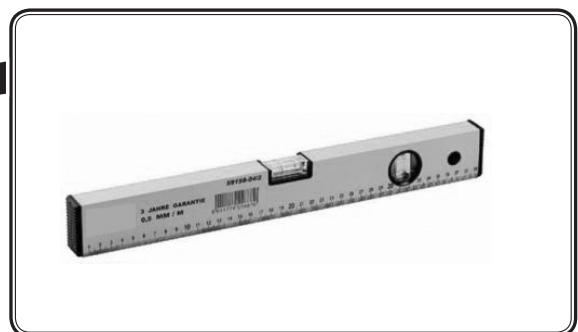
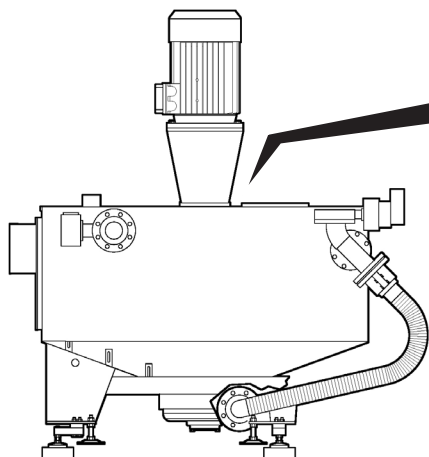
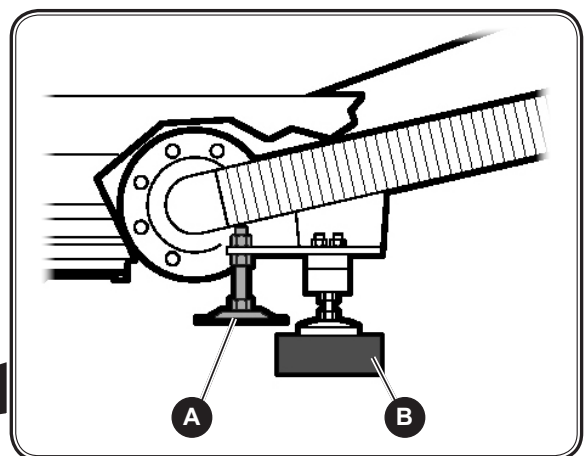
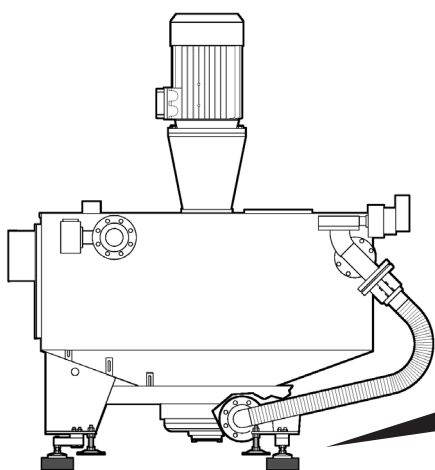

4.6.2 Installation of Flocculating agent tank (optional)

1. Secure the bracket "C" to a support "H" to prevent vibrations to Tank "D".
2. Prevent the pipe "E" connected to the pneumatic actuator "F" from coming into contact with the tank "G".

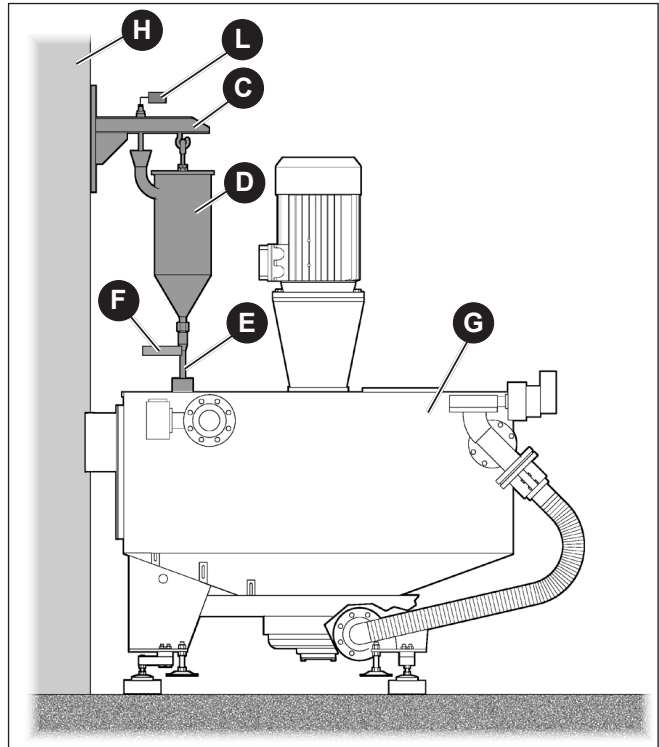

WARNING!

The Tank has a maximum capacity of 35 litres. The User is in charge of the power supply of the flocculating agent dispenser. Connect to Valve "L".

4.6.3 Installation of pipes

WARNING!

Use flexible pipes to avoid altering the load cells.

1. Install the pipe "M" for the water inlet

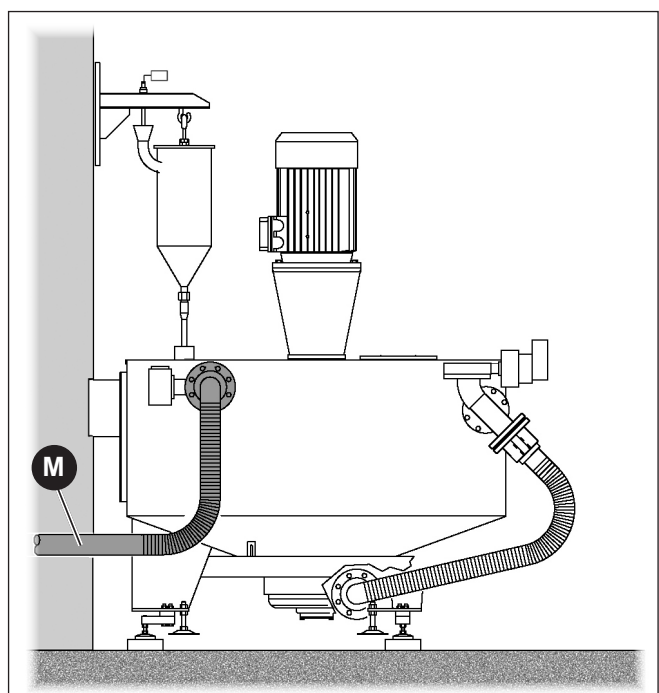

2. Install the pipe "N" for the slip discharge

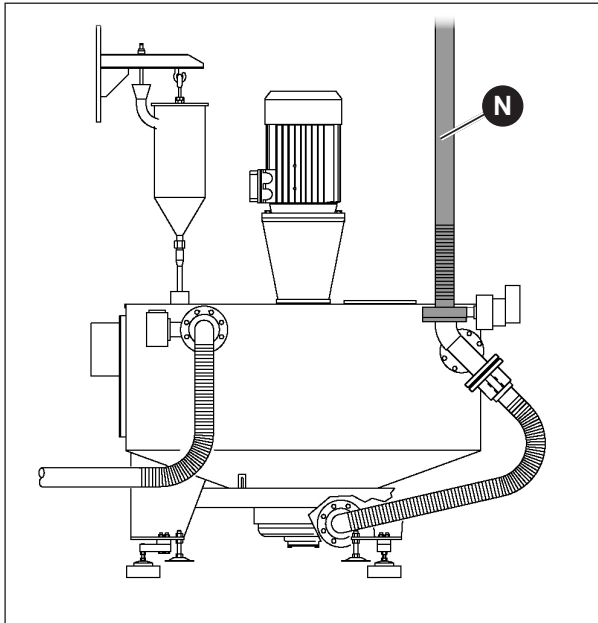

3. Install the pipe "P" for the powder inlet

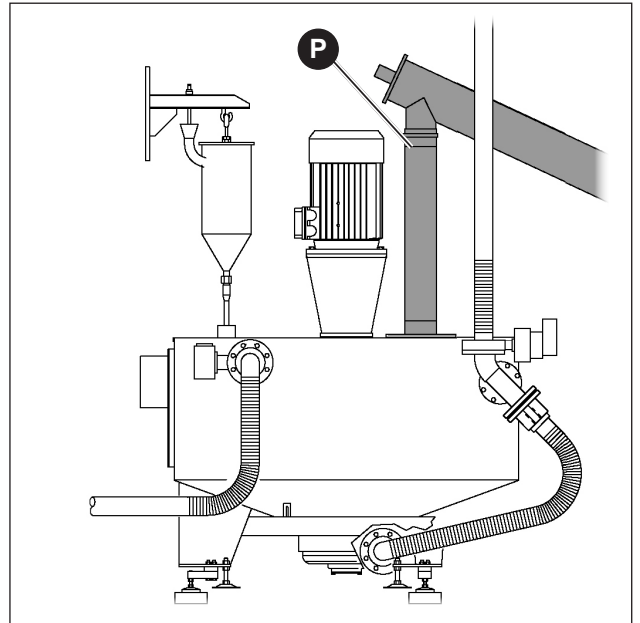

4.6.3.1 Powder supply connection

Connect to a powder feeder that conforms to the flow rates indicated in the table below (it is advisable to use frequency variators).

	EMT - ECD 4	EMT - ECD 5	EMT - ECD 6
Min and max powder flow rate (kg/min) Continuous and constant	from 5 to 10	from 10 to 20	from 15 to 35
Sufficient capacity for a work cycle (kg)	280	560	1000

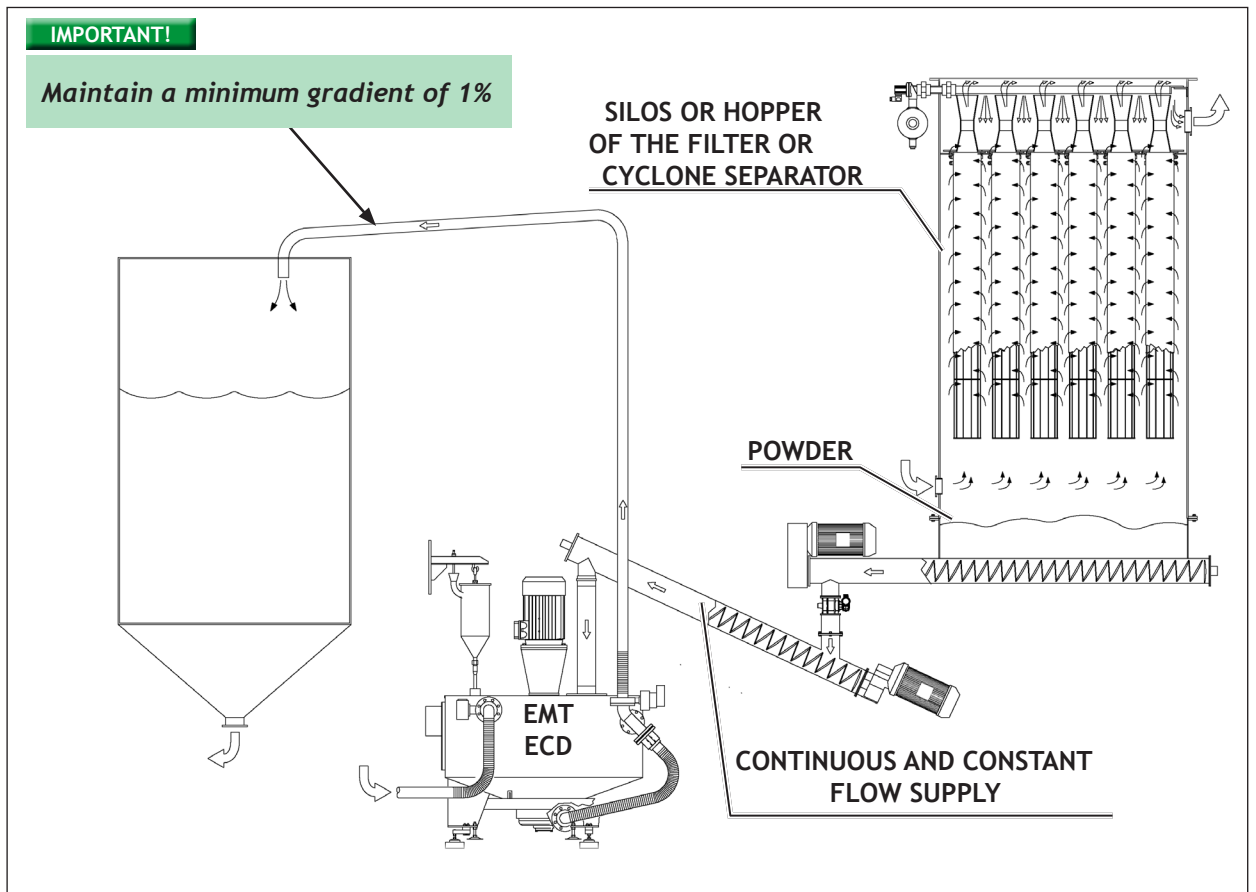

4.6.6 Electrical connection

WARNING!

The electrical connections and junctions must be set up by specialised staff (electrical technicians)

DANGER!

*For the Machine to work, the tank must be earthed.
The supply voltage must be stable +/- 5%
Failure to set up the connection to earth and/or exposed conductive parts may result in serious consequences for the Machine and the operator.*

Electrical connection procedure

Perform the electrical connection from the main Electrical panel consulting the wiring diagram: Attachment I to this manual.

4.6.6.1 Electrical connection of Load cells

WARNING!

To set up the electrical connection of the load cells, see the "ANALOGUE WEIGHT TRANSMITTER" Installation and use manual (request the document at service@vibrotech.biz)

The analogue weight transmitter is installed in the Electric-pneumatic panel on the Machine.

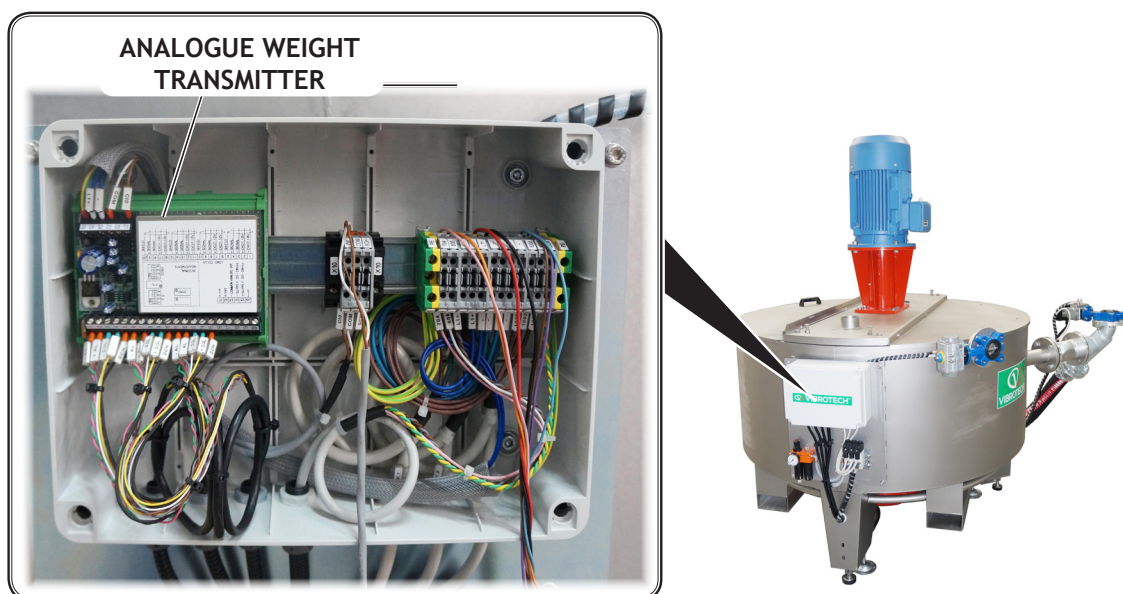

WARNING!

The connection between the pump and the electrical panel must be carried out with a shielded cable; also this cable must be installed separately from the signal cables and auxiliary cables.

4.6.7 Pneumatic connection

The place of installation must be equipped with a compressed air pneumatic system (pressure = 6 bar). Connect the pneumatic supply quick coupling to the pressure regulator (A) using a $\varnothing 8$ pipe.

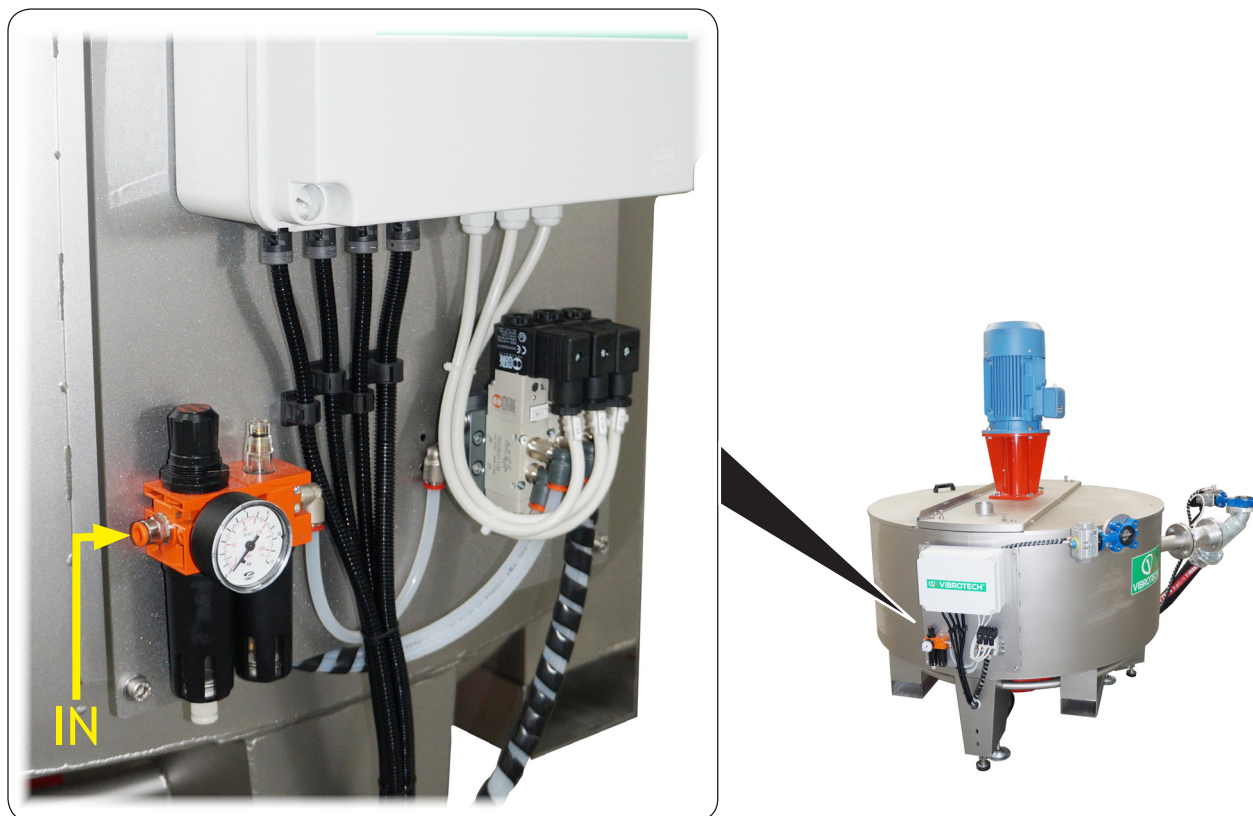

4.7 Commissioning

WARNING!

The construction, size and functional characteristics of the parts are such that they require the Customer/User to possess specific expertise that can only be guaranteed by the Service Technicians. If the User encounters difficulties performing the listed operations on his/her own, he/she is required to contact the manufacturer, to request information on training.

4.7.1 Checking correct activation

4.7.1.1 Checking the direction of rotation of the motor

Check that the direction of rotation of the Motor matches the arrow on the motor.

4.7.1.2 Checking operation of Load cells

IMPORTANT!

Make sure that the Load cells work properly by performing the "INITIAL SETTING" procedure described in the "Operator panel user manual" (request the document at service@vibrotech.biz)

5 Use and operation

5.1 Operating principle

IMPORTANT!

The Pump is always running during the cycle.

1. A preset amount of water is fed into the tank
2. Close the water flow;
3. Load the preset powder;
4. Close the powder flow and perform the final mixing;
5. Close the circulation valve;
6. Open the product discharge valve.
7. When the product is completely discharged and the minimum weight is restored, the discharge valve closes and the cycle starts over from the beginning.

The direction of flow of the liquids is shown in the figure below.

IMPORTANT!

The powder must be introduced in a time ranging between 30 and 60 minutes.

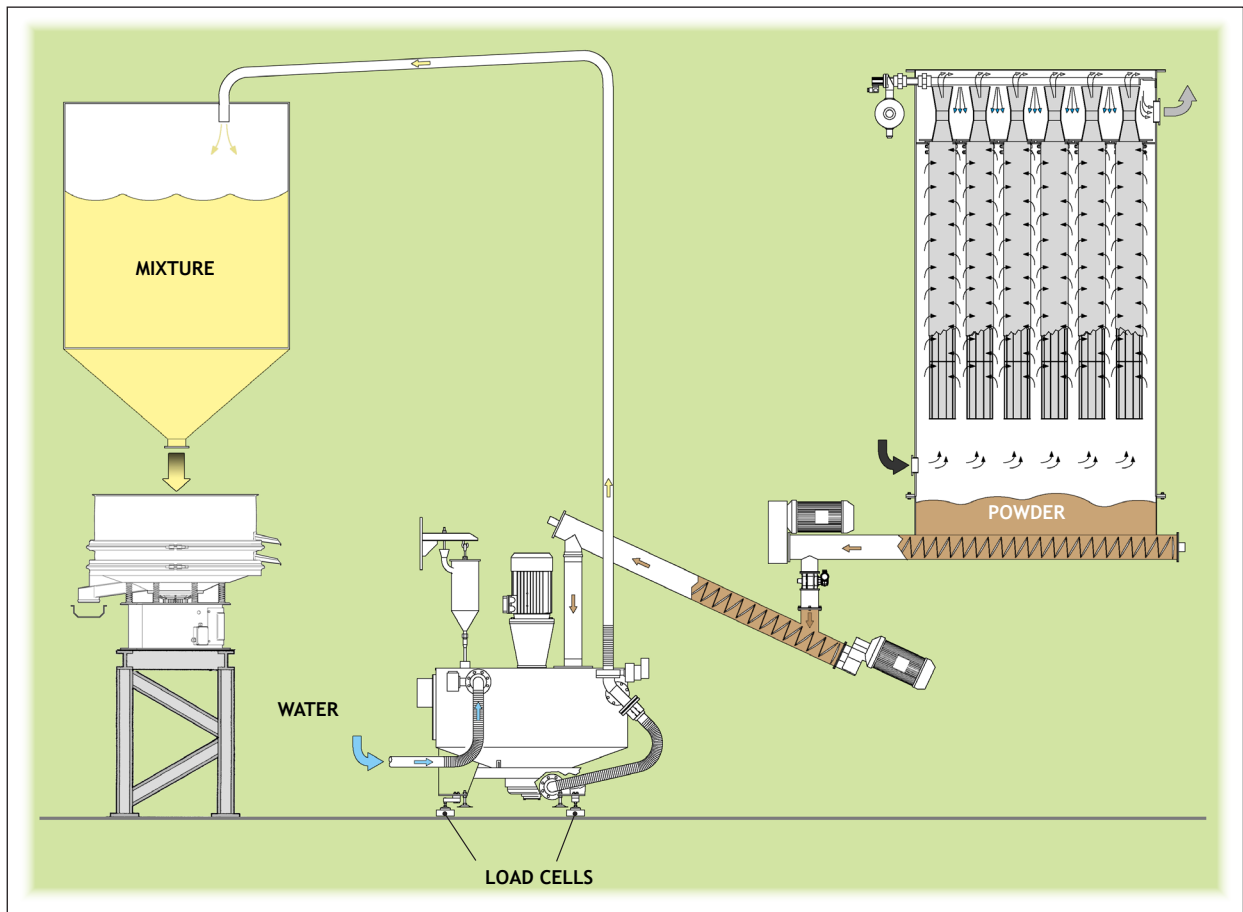

5.2 Control devices

5.2.1 Push-button board



AUXILIARY ON

24 Vdc voltage presence button with blue indicator light. Pressing this button enables the general auxiliary circuits of the Machine and allows you to start the work cycle or manual operations.

START CYCLE

Starts the Work Cycle.

STOP CYCLE

Timed-button actuation, stops the work process of the Machine.

There are three intervals to consider when pressing the button:

- 0(s)- 3(s): NO EFFECT
- 3(s)- 6(s): START WASH CYCLE
- More than 15(s): FORCED INTERRUPTION OF CYCLE, automatic operations RESET in progress.

MANUAL DISCHARGE

Discharges the product when the Machine is in the following modes:

- Machine in manual mode
- Machine stopped

The button does not work when:

- the Machine is in AUTOMATIC mode
- after having pressed the emergency button

Press the button once to start discharging, press it again to interrupt the process.

EMERGENCY

Red mushroom-head button. It is pressed in case of dangerous situations for the personnel for the purpose of stopping Machine operation.

Pressing this button prevents the auxiliary circuits of the Machine from being activated, cutting off power to all the moving parts. To reactivate the button, pull it and rotate it slightly clockwise.

5.2.2 Operator panel

IMPORTANT!

To know how the Operator panel works, request the "Operator panel user manual" at service@vibrotech.biz

5.2.3 Analogue weight transmitter

IMPORTANT!

To know how the Analogue weight transmitter works, request the "Installation and use manual" at service@vibrotech.biz

5.3 Operating procedures

IMPORTANT!

The Dissolver is operated from the control panel. Instructions are provided in the "Operator panel user manual" (request the document at service@vibrotech.biz)

5.3.1 Switch-on

This is done by turning the main switch on the Electrical panel to "1".

5.3.2 Starting the work cycle

Before starting the Machine, you must perform the initial setting and set the recipes. After having performed these operations, the wash cycle can be carried out.

IMPORTANT!

To perform the initial setting procedures, recipe settings and work cycles start up, see the "Operator panel user manual" (request the document at service@vibrotech.biz)

FREQUENCY INTERVENTIONS	OPERATIONS	PROCEDURES
At every use	Clean the Machine and the entire work area	A clean Machine in a work area clear of obstacles reduces the likelihood of accidents
	Checking protections	If their state of wear or operation is so precarious as to jeopardise operator safety, replace them. In particular, make sure the emergency button is working. <i>In all cases they must always be checked, cleaned and kept efficient.</i>
	Check the safety signs	Check the presence of the signs and their legibility

5.3.3 Normal voluntary stop

IMPORTANT!

To perform the Normal voluntary stop, see the "Operator panel user manual" (request the document at service@vibrotech.biz)

5.3.4 Emergency stop

The emergency stop is carried out by pressing the mushroom-head button on the pushbutton panel of the Electrical panel.

This condition causes all moving parts of the Machine to stop immediately, allowing it to be restarted only by a safety procedure described in par. 5.3.4.1

IMPORTANT!

The emergency stop must be carried out if the operators are in danger or there are anomalous situations for the Machine, for the purpose of immediately stopping the operating cycle. The emergency button must be pressed only in case of danger and not to stop regular Machine operation

5.3.4.1 Resetting after an emergency stop

- It must only be possible to reset the emergency stop button once optimal work conditions have been restored, after having verified the reason for the emergency stop.
- Pull and at the same time rotate the emergency button clockwise to reset it.

5.4 Additional operations

The work cycle includes the following additional operations:

1. Wash cycle
2. Forced interruption of the cycle
3. Forced emptying cycle

IMPORTANT!

Consult the "Operator panel user manual" (request the document at service@vibrotech.biz)

5.5 Using the work program

WARNING

Consult the "Operator panel user manual" (request the document at service@vibrotech.biz)

6 Maintenance

6.1 Safety warnings

DANGER!

- *Maintenance operations must be entrusted only to experienced workers (mechanical and/or electrical maintenance technician) who are familiar with the Machine.*
- *It is forbidden to perform any maintenance activities while the Machine is running and/or powered.*
- *Notify that maintenance is underway by putting up the necessary signs.*
- *Wear suitable protective equipment for the operations to be carried out.*
- *Provide suitable lighting in the work area where maintenance will be carried out. It is forbidden to use matches, lighters, torches, naked flames as means of lighting.*
- *Keep the maintenance work area clean and dry. Eliminate oil or lubricant stains.*
- *After having intervened on the electrical box or on the Electrical panel, always close it before restoring power and starting the Machine.*
- *Before restarting the Machine, make sure that the Pump protective cover is closed.*

6.2 General rules for good maintenance

To guarantee proper operation and to prevent faults, the maintenance technician must follow the instructions in the “SCHEDULED MAINTENANCE” table.

A table called “MAINTENANCE REGISTER” is provided at the end of the chapter and must be filled in by a person in charge of the machine, or by the person carrying out the maintenance work. It is advisable to keep the table up to date, especially during the warranty period.

Do not forget that fluctuations in temperature and in the operating conditions of the various components can have serious effects on the latter, and it is advisable in certain cases to perform maintenance operations on a more regular basis (the normal frequency of operations is provided in the table in terms of working hours) when the environmental and operating conditions demand it.

WARNING!

- *Failure to fill out the “MAINTENANCE REGISTER” will make the warranty null and void.*
- *Measures should be taken to immediately repair discovered defects or damage; alternatively, a report should be drawn up for later repairs.*
- *In the event of clear danger to the operator or the Machine, the Plant that the Machine operates on must be stopped and must not be restarted until the fault has been repaired.*
- *For optimal performance, keep the Machine clean. It is only possible to locate and repair faults quickly on a clean and easily accessible Machine, to prevent malfunctioning and to work in safety.*
- *When disassembling the components, avoid letting dust into the work areas and into the components themselves.*
- *When cleaning, do not use torn sponges, wet and/or abrasive cloths or rags with loose threads. Do not use jets of water on the electric motors and/or to clean the machine.*
- *Do not use fuel or inflammable solvents as a detergent. Only use commercial solvents authorised by the manufacturer that are neither inflammable nor toxic.*
- *Do not use jets of compressed air to clean the machine or its components. Dust must be removed with a vacuum cleaner, taking particular care of the electronic components; alternatively, use jets of dry air.*
- *It is advisable to replace the components with ORIGINAL SPARE PARTS.*
- *Use only fuses of the prescribed voltage.*
- *Arrange for the disposal of consumables and auxiliary materials as well as old parts, in accordance with the environmental regulations in force.*

6.3 Safe maintenance procedure

IMPORTANT!

The procedure provided below:

- is carried out from the pushbutton panel of the Electrical panel;
- it must be carried out before any routine or special maintenance operation. It entails disconnecting the Machine from all power sources.

1. Stop the Machine (Stop cycle)
2. Press the emergency button
3. Select "O" (OFF) from the main switch of the electrical panel
4. **Secure the main switch with a lock and keep the key until maintenance is over**
5. If maintenance is carried out on electrical parts, disconnect the electrical supply upstream.

IMPORTANT!

Only trained and authorised operators can work on live parts

6. If maintenance is carried out on pneumatic parts, discharge the air

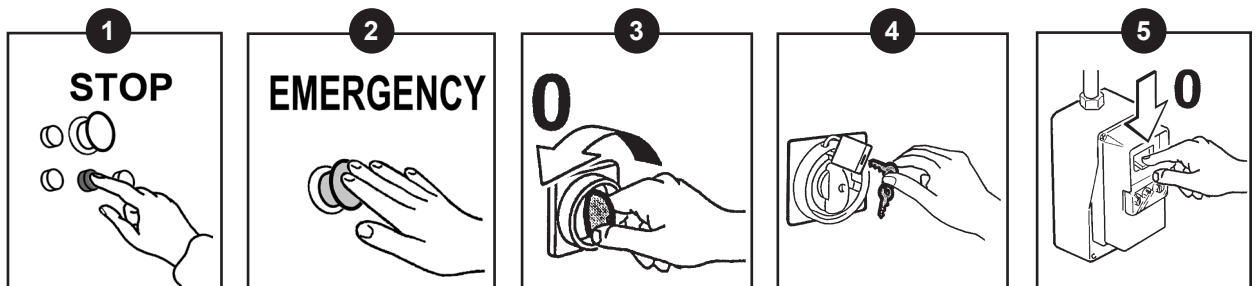

6.4 Scheduled routine maintenance

WARNING!

Observe the time frames provided in the **SCHEDULED MAINTENANCE** table
Before operating, it is important to observe the safe maintenance procedure (par. 6.3)

SCHEDULED MAINTENANCE		
FREQUENCY INTERVENTIONS (hours of operation)	OPERATION/INSPECTION	PROCEDURE
After the first 8 h then EVERY 24 h thereafter	Checking protections	Make sure that the protections are installed and their conditions, as described in par. 2.3.2
Every 200 h	Check the tightness of the parts	Make sure the bolts and screws are tight.
	Inspection of the electric parts	<p>Check the conditions of the electric cables connecting to the analogue weight transmitter and to the Electrical panel.</p> <p>Check the tightness of the screws: - relative to the switch clamps; - that connect the electric box power supply cables.</p> <p>Check the continuity of the PE circuit.</p> <p>CAUTION! CUT OFF THE POWER TO THE ELECTRIC PARTS</p>
Annually	General inspection	Perform annual maintenance by carrying out the activities listed above and verifying the state of all of the mechanical parts and the electrical equipment

6.5 Special maintenance

IMPORTANT

Special maintenance operations concern the breakage or adjustment of components where specific knowledge of the fault is required.

WARNING!

The safety warnings described at the beginning of the Chapter and in par. 6.3

6.6 Troubleshooting

PROBLEM	CAUSE	REMEDIES
The density of the slip is not constant.	The scale does not weigh	Check that the hydraulic connections are not too rigid
Too many lumps remain at the end of dissolving	The powder enters too quickly	Increase the powder feed time
	The powder enters irregularly	Introduce the powder continuously and constantly
	The final mixing time is too short	Increase the mixing time between the end of powder feeding and discharging.
	The powder does not get very wet	Install the flocculating agent feed unit
Electrical problems		Call the technical Service.

IMPORTANT!

If the problem found in the table was not solved, please contact the Technical assistance centre (SERVICE)

6.7 Dismantling

WARNING!



*Dismantling must be carried out by qualified personnel trained in correct work and handling methods.
Only use tools and lifting equipment that are suitable and compliant with the regulations and legislative provisions in force.*

To dismantle the Machine it firstly needs to be made inoperable by following the steps provided below.

- Prepare a large, clear work area
- Thoroughly clean the entire Machine, in particular the operating components
- Disconnect the Machine from the electrical mains, by removing the power cable from the terminal block in the electrical box and the power cable of the Electrical panel.
- Take down all of the parts of the Machine and divide them into waste and re-use
- Waste must be processed, disposed of or recycled according to its classification and the procedures set out by the laws in force in the country of Machine installation
- Collect the waste material in designated containers. Do not release it into the environment as this could cause a pollution hazard.

6.9 Ordering spare parts

IMPORTANT!

*To order parts, refer to Manual No. 2 by downloading it from the VIBROTECH portal
Please note that the Customer/User is always required to purchase original spare parts (or equivalent parts authorised in writing by the manufacturer) as the use of non original spare parts and/or their incorrect assembly relieve the Manufacturer of all liability, PARTICULARLY IN TERMS OF SAFETY PARTS.*

If necessary, contact:

VIBROTECH S.r.l.

Operational Headquarters: Via Don Pasquino Borghi, 4 - 42013 S. ANTONINO DI CASALGRANDE (RE) - Italy
Tel. +39 0536 82.37.76 - Fax +39 0536 81.20.09
www.vibrotech.biz - email: service@vibrotech.biz



VIBROTECH S.r.l.
Registered Office: Via Racchetta, 2 - int. 20 - 42019 Sassuolo (MO)
Operational Headquarters: Via Don Pasquino Borghi, 4 - 42013 S. ANTONINO DI CASALGRANDE (RE) - Italy
Tel. +39 0536 82.37.76 - Fax +39 0536 81.20.09 - www.vibrotech.biz - email: info@vibrotech.biz