

VIBRATING SCREEN FOR POWDER AND LIQUIDS

TWIN COMPATTO 600 - 900 1X

TECHNICAL FEATURES

DATA	U.M.	600	900
Number screening nets	N.	1	1
Screening surface	m ²	0,31	0,65
Power	kW	0,16+0,16	0,30+0,30
Centrifugal force	N	3806	8240
Vibrator motor	Type	MVE 200/15	MVE 400/15
Weight	kg	136	189

STRUCTURAL FEATURES

- Quick closures for fast disassembly without tools
- Made completely of stainless steel
- FDA approved seals
- Compact and easy to handle

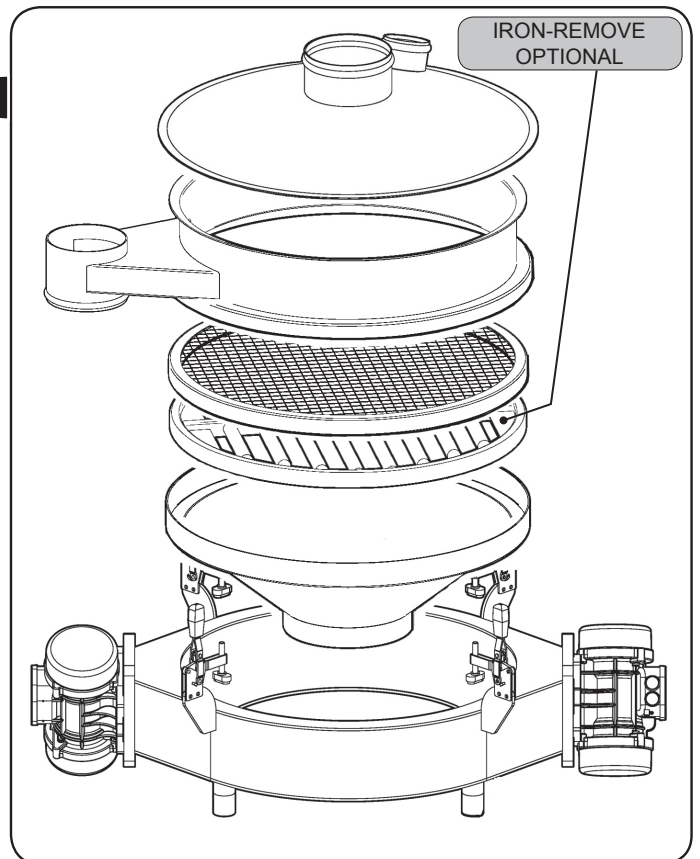
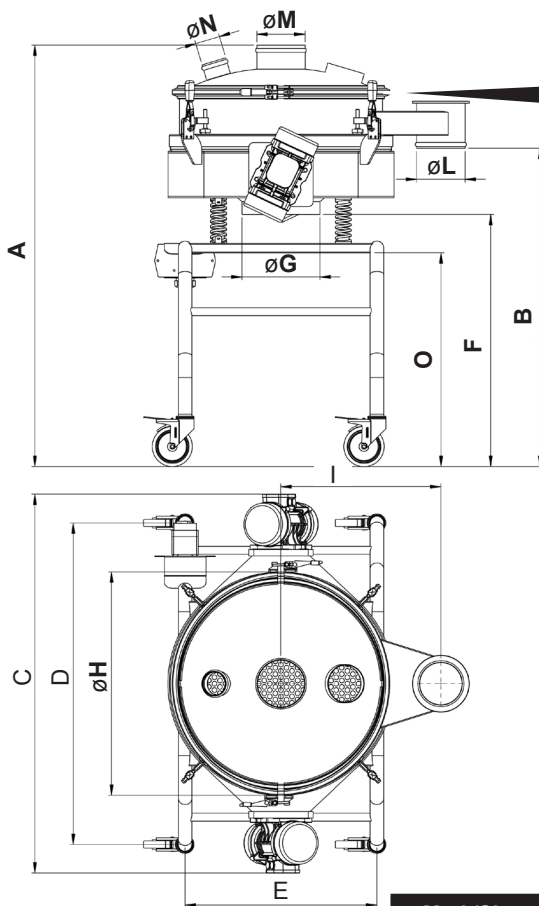

Mod./Size	A	B	C	D	E	F	ØG	ØH	I	ØL	ØM	ØN	O
COMP. Ø 600	1317	996	1185	1006	600	789	240	699	500	150	150	78	668
COMP. Ø 900	1339	1016	1508	1170	740	789	300	947	600	150	150	78	668

USE

- High performance control sieving
- Particularly suitable for the food and pharmaceutical industry

ACCESSORIES AND VERSIONS

- Dust-proof cover with inspection window and suction inlet
- Sieve with built-in deferrizer
- Various systems for automatically unclogging sieve meshes
- Wheeled trolley

The information is approximate - The guaranteed values are released by Vibrotech s.r.l. on request - It is forbidden to reproduce the document even partially.