

VIBRATING SCREEN FOR POWDER AND LIQUIDS

VB2 450-600 1/X

TECHNICAL FEATURES

DATA	U.M.	450	600
Number screening nets	no.	1	
Screening surface	m ²	0.104	0.264
Power	kW	0.18+0.18	0.16+0.16
Centrifugal force	N	374	388
Motorised vibrator	Type	MVE 200/3	MVE 200/4
Weight	Kg	45	90

STRUCTURAL FEATURES

- Open base with discharge outlet connected to the power feed.
- Lateral motor vibrators, IP65 protection rating, certified ATEX zone 22
- Parts in contact with product: AISI 304 stainless steel
- RAL 7035 painted carbon steel frame



VB2 450-600

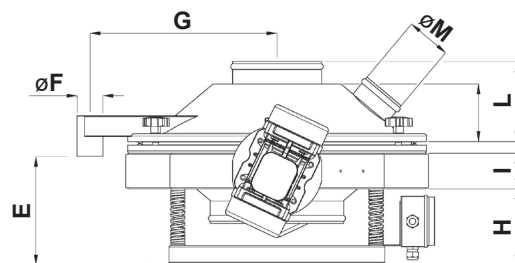
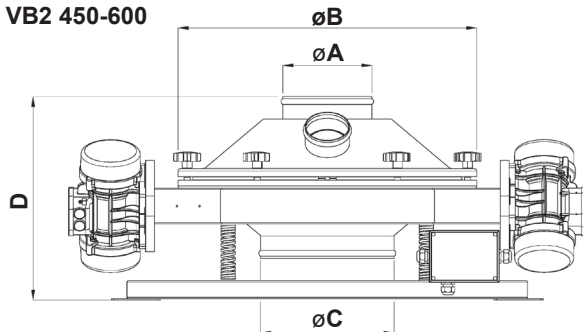

PLAN VB2 600

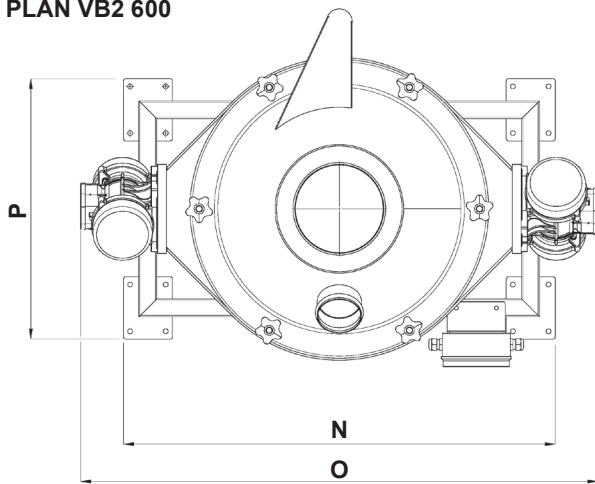

PIANTA VB2 450

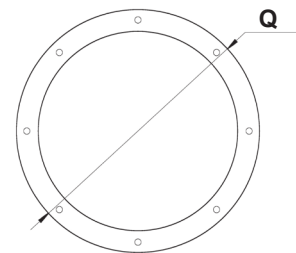

Mod./Size	øA	øB	øC	D	E	øF	G	H	I	L	øM	N	O	P	Q
450	200	454	300	312	179	60	303	108	50	135			870		455
600	200	671	300	457	244	60	420	171	80	180	100	970	1162	585	

USE

- Powder and liquid screening
- Press feed
- Mill discharge outlet

The information is approximate - The guaranteed values are released by Vibrotech s.r.l. on request-It is forbidden to reproduce the document even partially.